

Proceedings of the  
1973 Simulation  
Conference  
San Francisco  
1973

INTERACTIVE BUDGETING MODELS:  
A SIMULATION TOOL FOR MIS EDUCATION

Theodore J. Mock

University of California, Los Angeles

and

Miklos A. Vasarhelyi

Pontificia Universidade Catolica do Rio de Janeiro

Abstract

A relatively new and innovative educational approach in graduate information systems is discussed. The thrust of the approach is to have student groups design computer-based simulations of the budgeting processes of a firm in the form of an interactive budgeting model. These are applied to the areas of financial planning, control and managerial decision making. Several different approaches were suggested to and adopted by students as main design philosophies including modular planning and a matrix accounting system. The various implemented systems are described and their features are classified.

In its attempts to keep up with practice, the academic world is ever striving to develop improved pedagogical techniques and thus better-prepared information systems students. This paper reports on such a device, an Interactive Budgeting Model (IBM), used in the accounting-information systems program

within the Graduate School of Management.

One goal of this program is to expose students to online planning systems as described by Sackman and Citrenbaum<sup>1</sup>. If more and more implemented information systems incorporate online planning and

<sup>1</sup>Sackman, H. and R. L. Citrenbaum (Eds.), Online Planning, Prentice-Hall, 1972.

control features<sup>2</sup>, pedagogical adaptation is necessary. In this situation, an educational problem is to expose accounting and MIS students to the methodologies, man-machine interface, complexities and problems of system design in an academic environment. The approach described here is based upon student planning and implementation of a simulated, financially-oriented information system. The financial, budgetary focus of the project narrows the scope of possible projects and also has an additional benefit of requiring an in-depth knowledge of the accounting process (a skill frequently lacking in MIS and MBA students). A matrix accounting model is proposed to form the backbone of the system.

This paper is partitioned into three main sections including this introduction. The following section discusses the concept and implementation features of an Interactive Budgeting Model in terms of its educational objectives, its simulation features and its modeling features. The third main section of this paper describes actual projects designed and implemented by students at UCLA and Ohio State University in three different

courses. This summarization is intended to give the reader an idea of the specific features designed into these systems and their shortcomings. In addition, a time series comparison is presented of the features used at UCLA and Ohio State University.

Interactive Budgeting Models

The implementation of an Interactive Budgeting Model is the focus of approximately fifty percent of the student's effort in a graduate class at the masters level at UCLA. This class, called Information Systems for Planning and Control, is oriented towards exposing students to the problems of information systems design and corporate planning and control. This course is the second in a series of three where the first is oriented towards systems theory and the systems approach and the third is oriented towards problems of measurement in information systems.

In response to inadequacies in case, discussion and lecture approaches to the course, a tool was sought that would provide the experience students needed for systems analysis and system implementation of corporate financial information systems. Such a tool should have experiential features in which the student would encounter the problems inherent in systems design and analysis and also which would exhibit planning and control

<sup>2</sup>For example, Redwood, P.H.S., "APL For Business Applications," Datamation, May 1972, pp. 82-84; and "Litton's Electronic Information Machine," Business Week, March 28, 1970, pp. 158-160.

concepts. Such specifications led to the concept of the IBM, an interactive system for planning and control in a simulated environment.

Students were instructed to design and implement a conversational system which would allow a manager to interact with a terminal and assist in management decisions. The nature of this task and the boundaries of the problem were purposefully left ill-defined as the problem specification and contextual design phases are important experiences in the desired educational process. For example, Pounds<sup>3</sup> points out that "seldom if ever, do managers analyze or understand the sources of their problems," and "...the availability of formal problem solving procedures serves only to highlight those parts of the manager's job which these procedures do not deal: problem identification, the assignment of problem priority and the allocation of scarce resources to problems." Therefore, in an education process, accurate definition of a problem may hinder education in an area where the manager often is lacking.

Beginning with an ill-defined problem specification, students were then

<sup>3</sup>Pounds, W. F., "The Process of Problem Finding," The Industrial Management Review, Vol. II, No. 1, Fall 1969, pp. 1-21.

given several basic references<sup>4</sup> that may be useful in constructing their IBMs and were told that some quantitative techniques such as PERT, linear programming or regression may be profitably incorporated in the model.

The first two or three weeks of the class were then dedicated to teaching an appropriate interactive computer language. At UCLA, APL was used. This powerful interactive language is easy to learn and students, working in groups, tend to make up for their individual deficiencies.

Interactive computing and debugging permits students to obtain fast and accurate performance feedback on the main features of their models. In designing their system, the following were suggested as minimal design criteria:

1. Security features
2. File management of historical accounting data
3. A useful interactive decision aid
4. Planning and control features
5. Modular approach, matrix accounting structure.

Also, a list of possible modules for the IBMs were given to the students:

<sup>4</sup>Mattessich, R., Accounting and Analytical Methods, Richard D. Irwin, Homewood, Illinois, 1964; Butterworth, J. W. "The Accounting System as an Information Function," Mimeograph, University of British Columbia, June 1970; Ness, D. N., "Interactive Budgeting Models: An Example," Working Paper, M.I.T.

1. Output module
  - Display of financial statements, projected budgets, network schedules, selected display of underlying planning assumptions (e.g., rate of growth)
2. Input module
  - Reading and storing information
  - Building data bases
  - Retrieving information
3. Performance analysis modules
  - Calculating performance analysis ratios
  - Preparing output and management exception reporting
4. Incorporating transactions
  - Measurement of economic events
  - Periodic reporting
5. Building and using management science functions
  - L.P., statistical analysis, graphics, charts, discounting
6. Control and security features
7. Specific planning and forecasting aids
  - Regression, exponential smoothing, consensus (Delphi) techniques
8. Programmed decision rules
  - Exception limits, cash constraints

As is demonstrated in a following section of this paper, these suggested module specifications inspired a large variety of IBMs.

In implementing the tasks involved in constructing such an IBM, the student groups had to consider a series of system design problems including problem and project specification and management. These are discussed from a pedagogical viewpoint.

First, the student team had to decide on what type of organization and which specific planning and control

problems they wanted to model. Some chose a simplified model of an entire firm or department and concentrated on implementing several management science techniques. Others decided to simulate a small part of a large system and attempted to attack its problems extensively. Part of the learning gained from this step in the model development is the need to specify, limit and dissect the possible problems to be tackled. A main cause of difficulty and frustration in such projects was tackling too large a problem and the eventual difficulty of implementation within time constraints.

MIS classes usually draw students with a variety of backgrounds including accounting, computer methods, marketing and behavioral science. Such heterogeneity results in a labor distribution problem. Frequently, students specialize such that those interested in computer methods concentrate on programming while accounting majors study information flows and reporting techniques. In contrast some groups divide programming tasks evenly among their constituents. Either approach frequently generates serious coordination problems as certain parts of the project are completed on schedule and others are not.

Once a group settled on a problem area, problem focus was needed. Groups

frequently tried to overachieve and during the later stages of the project began to realize that their objectives were not realistic and should be redefined. Part of the difficulty of the instructor's task was to warn students about such risks without undercutting the learning potentiality of these experiences.

The experience that an IBM project lends to the students in terms of group processes is certainly an important educational aspect in MIS education. Although there was a definite task and deadlines and assignments in the beginning of the course, there was often too many ideas and little consistency among them. Also there were emerging leadership patterns and conflict for leadership roles. Evidence of this was that groups sometimes could not reach consensus and attrition occurred. Management and coordination problems always seemed to occur. Students frequently experienced the point that Argyris<sup>5</sup> makes "... the introduction of a sophisticated information technology is as much an emotional human problem that requires interpersonal competence (as well as technical competence) and that requires

<sup>5</sup> Argyris, Chris, "Management Information Systems: The Challenge to Rationality and Emotionality," Management Science, Vol. 17, No. 6, February 1971, pp. B-275-292.

661  
knowledge about the human aspects of organizations such as personality, small groups, intergroups and living systems of organizations norms."

#### The Underlying Matrix Accounting Structure

The IBM concept has been suggested<sup>6</sup> as a technique to design surrogate information systems and decrease software development costs. In this era of rapid change in which education has lagged technological development, new tools for education are needed. Many principles in the design of large scale software information systems are not theoretically sophisticated and may even be counter-intuitive in nature due to the intricate interconnection of different system components.<sup>7</sup> The same may also be true in the design and integration of large scale systems where a large number of components interact and factors are interconnected. In such a situation the utilization of simulation technology for education and for the design of large scale software systems seems to exhibit great value.

<sup>6</sup> Vasarhelyi, M. A., "Simulation - A Tool for Pre-Implementation Testing of Large Scale Software Systems," Winter Simulation Conference, 1971.

<sup>7</sup> Forrester, Jay W., "Alternatives to Catastrophe - Understanding the Counter-intuitive Behavior of Social Systems," Technology Review, January 1971.

The matrix approach to accounting is suggested as the backbone of the IBM for several reasons, some of which have been alluded to earlier. Essentially a matrix model reveals the entire (wholistic) impact of each actual (or planned) accounting transaction on the entire set of financial reports or budgets. Thus the student must relate to the entire financial system and the impact of planning assumptions and decisions upon this system.

The matrix accounting approach considers entries in the firm's chart of accounts as a vector of period transaction amounts (T) multiplying an incidence matrix (I) composed of zeros and plus or minus ones.<sup>8</sup> The vector is equivalent to the possible accounting actions in the firm and the incidence matrix indicates which of the accounts of the firm are affected by such financial transactions. All account balances (B) at the end of period t are given by the identity  $B_t = T_t I + B_{t-1} C$ , where C is a matrix which closes nominal accounts. For a computerized system t may represent "real time," a day, a week or whatever and T may be projected (for planning) or actual financial transactions. The matrix approach can be extended to include policy changes in the firm.

<sup>8</sup> Butterworth, J. W., op. cit.

Such a methodology allows users to design and, through a simulation, consider the effects of policy changes over projected, proforma or budgeted financial statements. Interesting effects can be obtained by augmenting such models with OR techniques and interrelating interactive policy changes with partial optimization of system parameters. The utilization of simple linear projections can be made more realistic by the utilization of exponential, logarithmic or exponentially smoothed functions. Clearly, however, the monitoring features of interactive simulation are advantageous as the type of projections can be adapted to the realistic overview of the manager. Such powerful tools have been utilized in the construction of IBMs as are described in the next section of this paper.

Implemented Models

At this time, ten student IBMs have been designed. In the remaining part of this paper, these systems are summarized and contrasted. Focus is placed upon the underlying computer language and system characteristics and upon implemented simulations and man-machine considerations.

The projects will be discussed in terms of the three different classes where this technique was utilized. Computer capabilities and environmental

factors were somewhat different for each class, thus providing an interesting comparative, longitudinal study. The first projects were developed during the spring quarter of 1971 at UCLA only four months after APL had been "brought up" on campus. The IBMs were implemented on the university's IBM 360/91 using APL which, at that time, had neither file nor fast formatting capabilities. As APL was the only interactive language available at UCLA, language choice was not a problem.

The second set of projects were developed at Ohio State during winter quarter, 1972. At that time, computing was carried out on an IBM 370/165 and the Time Sharing Option (TSO) was up and running. Although BASIC and TSO FORTRAN and PL/1 were available, all student groups selected the CPS (Conversational Programming System) language which is essentially an interactive subset of PL/1. In comparison to UCLA, the main constraints of the OSU system capabilities were: 1) limited selection of business oriented preprogrammed sub-routines, 2) in comparison to APL, CPS is a less powerful language and requires considerably more code, and 3) relatively slow response times. On the positive side, the OSU system was more stable and provided file capabilities so

necessary for any realistic financial data base.

The third set of projects were developed during spring quarter 1972 at UCLA. This group used the same computing hardware previously described except by this time a preprogrammed fast formatting routine and file capabilities were available.

In terms of overall results, the scope, insight and technical quality of the IBMs was quite impressive, even for groups of graduate MIS students. This is evident in the sample material that follows. As expected, most problems were related to intragroup conflict or inability to establish realistic project goals and scope. The rather tight schedule facing the students was as follows:

<u>Course Week</u>	<u>Topic and Assignment</u>
1	General, but purposely vague, description of IBM concept, project requirements, and possible design criteria
1,2, & 3	Review (learn in many cases) appropriate computer language
3	Project plan and description, including PERT-type schedule, due and presented during class (this of course facilitated cross fertilization of ideas)
6	Oral report on progress and problems
9	Class demonstration of completed IBMs
10	Written reports including sample output, documentation and project critique

### Project Summaries

As one would expect, a wealth of data exists on the ten projects. In an attempt to reduce these data, a taxonomy of each IBM is included in Table I. The taxonomy includes available computer system capabilities, description of the simulated entity, IBM modules, planning and control features, system features and problems.

Upon examining this summary, the following patterns emerged. First, the latter IBMs are more sophisticated than the earlier ones. Probably this was due to an increasing ability on the instructor's part to describe alternatives. Another factor was the improved system capabilities, particularly file management.

Although simulation modules were suggested either to incorporate environmental uncertainty or to test strategy alternatives, no group implemented such a module due to its intrinsic complexity. More importantly, design of the man-machine interface was neglected. For example, the conversational features of the executive modules were generally inadequate. This is disconcerting as a suggested systems criterion was "a useful interface decision aid," i.e., user oriented. One explanation is that in the initial stages of such projects,

participants tend to be "systems biased" and thus they focus on implementing the forecasting, accounting, data base and reporting systems. Such oversights and biases were fed back to the groups as part of the learning process.

### Sample Interactive Budgeting Models

A sample of some of the IBM materials follow. These include a project plan (Exhibit 1), a CPM-type schedule for an IBM (Exhibit 2) and sample output of two systems.



TABLE I  
TAXONOMY OF PROJECT CHARACTERISTICS

<u>Computer System and Options</u>	<u>Organization Description: Real or Fictitious Firm</u>	<u>System Modules (*indicates planned but not implemented)</u>	<u>Other Planning and Control Features</u>	<u>Design Features and Problems, Miscellaneous Data</u>
<u>Class 1, UCLA, Spring 1971</u>				
IBM 360/91 APL without fast formatting options  32K workspaces	<u>Group 1</u> Fictitious TV manufacturer with 3 production lines (Risk Inc.)	Operational Control Optimization of production re L.P. Effect on budgets, sales forecasts Management Control (MC) Retrieval of current financial statements Stochastic sales forecast Ratio analysis of financial budgets Strategic Planning (SP) Present value analysis of investments GNP based long run sales forecast	User can resort to and test a variety of planning assumptions.  Overall function TOT integrates other modules and facilitates comparison of forecasts derived from SP and MC including implications.	<u>System Requirements</u> Needed more than 1 workspace, WS FULL ERRORS.  Use of preprogrammed LP and REG library routines.  Developed from total systems philosophy.  What-if (sensitivity) analysis implemented.
	<u>Group 2</u> Fictitious, Small retailer	Sales forecasts and derived financial budgets Financial reporting Control (planned only)	<u>Planning: Complete transaction based financial plans (flexible horizon)</u>	1 workspace No file or security considerations Output fairly well formatted Control features (module) incomplete Limited decision aid Sensitivity aid
	<u>Group 3</u> Fictitious, Plate Glass Co., focus on 5 process production dept.	Forecasting Sales, Cash Flow (4 periods) <u>I/S and Balance Sheet</u> Sales forecast based on macro economic data, historical company data, e.g. UCLA business forecast		1 workspace Poorly formatted output Internally (WS) managed data file

(60)

TABLE I (CONTINUED)

Computer System and Options	Organization Description: Simulation of Real or Fictitious Firm	System Modules (*indicates planned but not implemented)	Other Planning and Control Features	Design Features and Problems, Miscellaneous Data
	<u>Group 3 (Continued)</u>	Process cost analysis (including change of costing rates) (cost and transfer price) Variance analysis of budget to historical and actual to budget (both absolute and relative)		
		<u>Class 2, OSU, Winter 1972</u>		
IDM 370/165 CPS language (Conversational Processing System, subset of PL/1)  Operated under TSO	<u>Group 1</u> Real Highway Construction Company focus on contract bidding- cost control and performance analysis. Simplified contract developed.	*L.P. generation of optimal bid Base generation and management Data base retrieval of cost and interactive bid generation Cost measurement, variance reporting and data base update		Significant code was required, especially for file management. Integration was not accomplished. Significant file loss problems were encountered. Response time was a problem, particularly to retrieve file data.
Some File Capabilities, Limited Preprogrammed Public Routines	<u>Group 2</u> <u>A-Loss Co.</u> Fictitious, single product manufacturing company.	Sales forecast Financial forecast (overall budget) Transactions (accounting) Control and performance reports Executive (overall integration and sensitivity analysis and security)	Sensitivity of budget-to-budget assumptions (e.g. collections schedule) Management by exception	System derived constraints: Quarterly updating Maximum of 30 accounts and 20 transactions Maximum of 5 systems functions  Other desirable features: Dating function Audit trail Security log.
	<u>Group 3</u> <u>MDA Co.</u> , Real Ohio non-ferrous jobbing foundry	Data base (actual historical data) *Integrated cost control system Accounting module Regression analysis and forecasting	Monte Carlo Simulation of financial results with interval estimates.	Information needs derived from management needs. Design focus on what-if capabilities. Integration of modules never really completed.

TABLE I (CONTINUED)

Computer System and Options	Organization Description: Simulation of Real or Fictitious Firm	System Modules (*indicates planned but not implemented)	Other Planning and Control Features	Design Features and Problems, Miscellaneous Data
	<u>Group 3</u> (Continued)	Budgeting Interactive Control (executive) Report generator		Significant file errors and loss.
		<u>Class 3, UCLA, Spring 1972</u>		
IBM 360/91 APL/360 with PLUS/ FILE option and fast formatting (AFMT) 48K work- spaces	<u>Group 1</u> Real Organization AISRP Research Center, UCLA	Security Budgeting Control	Comparative budgets (updated vs original)	Simplified funds-oriented accounting structure
	<u>Group 2</u> Real firm construction contracting, fictitious data	Executive Planning Transactions Control	Regression forecast of So. California construction. Cash focused financial control.	Designed re interview of management's information needs. Desirable additions include user-control over forecast parameters, explicit sensitivity comparisons.
	<u>Group 3</u> Real problem, planning and control system for movie production	File creation (selection of movie activities and levels) File Update (actual data) Cine-budget Printout	PERT/Cost schedule Progress and variance reports Completion performance reports	Extensive file utilization.
	<u>Group 4</u> Real organization, Health research project management	Security Executive query Data base management Management module	1-year program budget, 5-year program forecasts Minimal control implemented	Program budget (PPB) orientation Focus on information retrieval rather than decision aid Significant module interface problems System output bound.

EXHIBIT 1

Project Plan, Group 2, Spring 1972, UCLA

OBJECTIVE

The objective of our project is to design an interactive budgeting and control system to meet the information needs of the President of an insulation contracting firm.

SCOPE OF OUR DESIGN

The system that we are designing is concerned mainly in providing the President with information to help him in the area of management planning and control. It designed around an analysis of his major decisions in that area, the process he used to make those decisions, and the information he feels he requires. Since the manner in which each branch is handled is similar, we have designed the system with reference to only one branch with the assumption that by duplication it could easily be expanded to handle all the branches. We have broken the system into five major modules which are described below.

MAJOR MODULES AND THEIR FUNCTIONS

Forecast Module

The forecast module is to be used to estimate quarterly sales for the next 12 months. This will then be broken down into monthly sales. The method of linear regression is to be applied, utilizing those factors that we feel are appropriate - interest rates, building permits, etc. Sensitivity analysis will be available to the manager. Using sales forecast as a basis we will then be able to forecast other accounts and prepare budgets.

Transactions Module

The Eutterworth Matrix System of accounting will be used in this module to handle the traditional accounting transactions and produce the monthly and yearly financial reports.

Control Module

This module will produce the needed reports to show variances from the budgets or standards. Certain general reports will be produced automatically at the end of each month or whenever desired, and other more detailed reports will be available on request.

General Reports to Be Produced

- Variation in Income statement and Balance Sheet accounts as compared to budget - monthly and year to date.
- Cash forecast for next three months
- Signed sales contracts for next three months as compared to estimated sales for next three months.
- Profit as compared to budget and previous year.
- ROI as compared to expected standard
- Changes in current ratio
- Changes in working capital
- Accounts Receivable and Inventory turnover as compared to standard
- Inventory level as compared to standard

Security Module

This module will handle security procedures to insure that it cannot be accessed by unauthorized individuals.

Executive Module

This module will tie in all the other modules and make them part of an integrated system that is easy to use and change.

EXHIBIT 2  
Group #1 IBM Project,  
CPM Chart  
Spring 1971, UCLA  
Critical Path = 42 Days

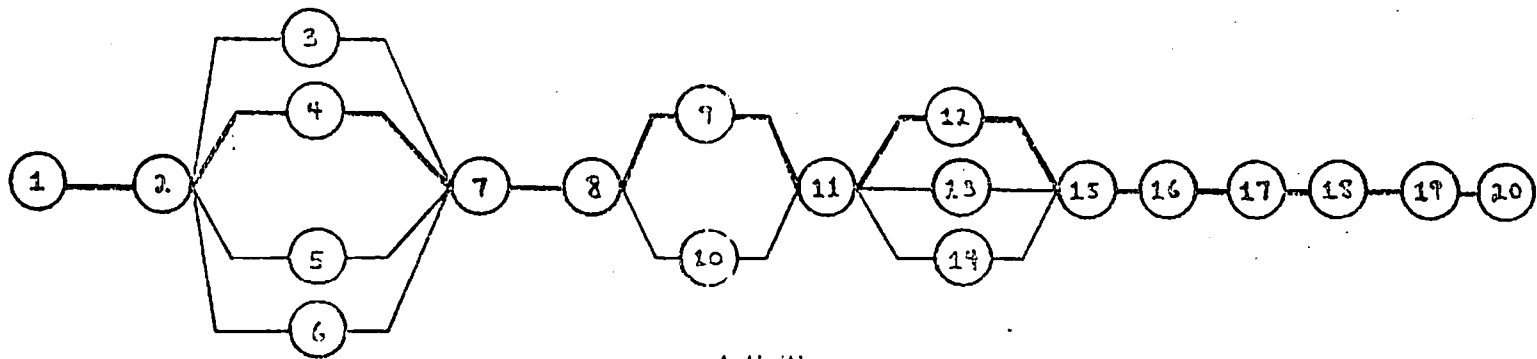

Activities

- |                                                                                                                                                                                                                                                                                                                                                                                                                                                           |                                                                                                                                                                                                                                                                                                                                                                                                                     |
|-----------------------------------------------------------------------------------------------------------------------------------------------------------------------------------------------------------------------------------------------------------------------------------------------------------------------------------------------------------------------------------------------------------------------------------------------------------|---------------------------------------------------------------------------------------------------------------------------------------------------------------------------------------------------------------------------------------------------------------------------------------------------------------------------------------------------------------------------------------------------------------------|
| <ol style="list-style-type: none"> <li>1. Begin project</li> <li>2. Establish initial IBM concept</li> <li>3. Build data bases</li> <li>4. Design operational control module</li> <li>5. Design management control module</li> <li>6. Design strategic planning module</li> <li>7. Consolidate modules into IBM concept</li> <li>8. Resolve discrepancies</li> <li>9. Initial logic of interactive linkage</li> <li>10. Enrich initial concept</li> </ol> | <ol style="list-style-type: none"> <li>11. Finalize IBM concept</li> <li>12. Finalize operational control module</li> <li>13. Finalize management control module</li> <li>14. Finalize strategic planning module</li> <li>15. Consolidate modules</li> <li>16. Finalize interactive linkage</li> <li>17. Test IBM</li> <li>18. Debug model</li> <li>19. Prepare final report</li> <li>20. Turn-in report</li> </ol> |
|-----------------------------------------------------------------------------------------------------------------------------------------------------------------------------------------------------------------------------------------------------------------------------------------------------------------------------------------------------------------------------------------------------------------------------------------------------------|---------------------------------------------------------------------------------------------------------------------------------------------------------------------------------------------------------------------------------------------------------------------------------------------------------------------------------------------------------------------------------------------------------------------|

Of the many interesting projects, the following one was selected as it is representative of an early project and

includes a rather descriptive executive module.<sup>9</sup> Upon initiation the following (Exhibit 3) is received by the user.

EXHIBIT 3

THIS IS AN INTERACTIVE BUDGET MODEL FOR RISK INC.  
THE MODEL DOES MANY MAGICAL AND EXOTIC THINGS, AS FOLLOWS:

PRIOR YEAR BALANCE SHEET: TYPE BAL70  
PRIOR YEAR INCOME STATEMENT: TYPE INCOME70  
CURRENT DATA:

TO ANALYZE CURRENT OPERATIONS YOU MUST SUPPLY CERTAIN VARIABLES. THIS ALLOWS YOU TO ENTER WHAT YOU THINK THE ACTUAL FIGURES ARE, OR ENTER THE POTENTIAL VALUES. IT IS SUGGESTED THAT YOU BEGIN BY ENTERING THE ACTUAL VALUES AND THEN VARYING ELEMENTS AS DESIRED TO OBSERVE THE EFFECT ON THE OVERALL PICTURE.

THIS MODEL IS DIVIDED INTO THREE BASIC MODULES:

OPC - THIS MODULE CONCERNS PRODUCTION ELEMENTS AND EFFECTS ON COST OF GOODS SOLD. TYPE OPC FOR THIS MODULE ALONE.

MC - THIS MODULE PROVIDES BALANCE SHEETS, INCOME STATEMENTS, SALES FORECASTS, ETC. TYPE MC FOR THIS MODULE ALONE.

SP - THIS MODULE CONCERNS STRATEGIC PLANNING AND PROVIDES LONG RANGE PLANNING TOOLS. TYPE SP FOR THIS MODULE ALONE.

EACH MODULE WILL DESCRIBE ITS VARIOUS FEATURES FOR YOU WHEN CALLED.

IN ADDITION, YOU CAN GET A BROAD OVERVIEW BY TYPING TOT. USING THIS YOU CAN FOR EXAMPLE VARY PRODUCTION COSTS AND IMMEDIATELY SEE THE EFFECTS ON INCOME WITHOUT HAVING TO CALL EACH MODULE SEPARATELY.

YOU MAY BEGIN NOW -- HAVE FUN.

Given a general overview of the system the user is ready to begin. For the neophyte, historical financial statements are available such as last year's income statement:

SALES	2700400
	-----
COST OF GOODS SOLD	1326000
SELLING, ADMIN EXPENSE	481000
INTEREST EXPENSE	13000
EARNINGS	880400
TAXES ON INCOME	396160
	-----
NET INCOME	484220
	=====

Note that formatting options were not available to this group and thus the units in the preceding statement do not line up. To access the operating modules of this system, further documentation is needed. The various modules were accessed as displayed in Exhibit 4.

<sup>9</sup>Gordon, K.A., S. Archuleta, M. Ishii, "The Interactive Budget Model: A Conceptual Study," Term Project, Professor T. J. Mock, Graduate School of Management, University of California, Los Angeles, June 1971.

OPERATIONAL CONTROL:

OPC

YOU HAVE ACCESSED THE OPERATIONAL CONTROL MODULE. THIS MODULE FUNCTION IS TO ASSIST IN PRODUCTION PLANNING USING A LINEAR PROGRAMMING ROUTINE TO MAXIMIZE A PROFIT-FUNCTION. YOU MAY VARY FACTORS OF PRODUCTION SUCH AS LABOR HOURS AND RAW MATERIALS AVAILABLE. THE PROGRAM ALSO INTERACTS WITH THE LONG RANGE-SALES-FORECAST TO PROJECT PRODUCTION COSTS BASED ON PROJECTED SALES.

TO OPERATE THIS MODULE TYPE SMCOST

SACOST

THIS PROGRAM WILL CALCULATE THE OPTIMAL COMBINATION OF PRODUCTION

RESOURCES USED IN THE MANUFACTURING PROCESS OF THREE TELEVISION-

MODELS: X1-BLACK AND WHITE, X2-PORTABLE COLOR, X3-DELUX COLOR.

THE OBJECTIVE FUNCTION IS TO MAXIMIZE  $P = 15X1 + 25X2 + 27X3$ , WHERE P

IS THE TOTAL CONTRIBUTION TO OVERHEAD AND PROFIT, AND X1, X2, AND

X3 ARE THE NUMBER OF UNITS TO BE PRODUCED TO MEET THIS OBJECTIVE.

THE OBJECTIVE FUNCTION IS BASED ON THE FOLLOWING DATA:

X1	X2	X3
90	350	425
71	325	398
19	25	27

CONTRIBUTION TO OVERHEAD AND PROFIT/UNIT

VARIABLE COST PER UNIT

SELLING PRICE PER UNIT

LABOR A	5	5	3
LABOR B	8	12	14
LABOR C	12	14	14
MATERIAL D	10	12	12
MATERIAL E	15	18	20
MATERIAL F	1	1	1

TO PRODUCE ONE UNIT:

LABOR A

LABOR B

LABOR C

MATERIAL D

MATERIAL E

MATERIAL F

INPUT PARAMETERS G, H, I, J, K, AND L, THE TOTAL LABOR HOURS

AND MATERIAL UNITS AVAILABLE.

10000

18000

24000

21000

25000

20000

o  
o  
o

EXHIBIT 4 (CONTINUED)

MANAGEMENT CONTROL:

MC

YOU HAVE ACCESSED THE MANAGEMENT CONTROL MODULE.  
MODULE FEATURES ARE;

1. CONSOLIDATED BALANCE SHEET - IN ORDER TO GET CURRENT STATUS  
TYPE BALCUR. IF YOU WANT TO ENTER VARIABLES TYPE BALVAR.
2. INCOME STATEMENT - IN ORDER TO GET CURRENT STATUS TYPE INCCR.  
IF YOU WANT TO ENTER VARIABLES TYPE INCVAR.
3. SALES FORECAST - TYPE FORE AND YOU WILL BE ASKED TO ENTER PROJECTED  
GROWTH RATE AND ACCEPTABLE STANDARD DEVIATION. THE PROGRAM WILL THEN  
PROJECT MONTHLY DOLLAR SALES FOR THE PERIOD YOU SPECIFY AND PROVIDE  
YEARLY TOTALS. YOU MAY THEN SPECIFY PERCENTAGE OF SALES BY MODEL AND  
GET SALES TOTALS BY MODELS, INCLUDING QUANTITY OF EACH MODEL SOLD.
4. CURRENT RATIO - TYPE CR.
5. ACID TEST RATIO - TYPE AT.
6. RETURN ON ASSETS - TYPE ROA.
7. EARNINGS ON STOCK - TYPE ES.

FORE ROUTINE (SALES FORECAST) IN MC MODULE:

FORE

SALES FOR 1970 WERE 2,700,400. FORTY-FIVE PERCENT WERE PORTABLE COLOR,  
THIRTY-FIVE PERCENT WERE DELUXE COLOR, AND TWENTY PERCENT WERE BLACK AND WHITE.  
ENTER BELOW FIGURES FOR PROJECTED SALES GROWTH (PERCENT YEARLY), ALLOWABLE  
DEVIATION (FOUR FIGURE INTEGER), AND LENGTH OF FORECAST IN YEARS.  
PROJECTED GROWTH RATE:

:

.05

DEVIATION:

:

1000

FORECAST PERIOD (INTEGER REPRESENTING YEARS):

:

2

SALES FORECAST  
(BASED ON 5 PERCENT SALES GROWTH)

YEAR : 1

JAN 236290

FEB 236302

MAR 236105

APR 236772

MAY 236279

JUN 236052

JUL 235876

AUG 236733

SEP 235859

OCT 236286

NOV 236170

DEC 236063

TOTAL SALES: 2834787



EXHIBIT 4 (CONTINUED)

STRATEGIC PLANNING:

SP  
YOU HAVE ACCESSED THE STRATEGIC PLANNING MODULE.  
THIS MODULE OFFERS LONG RANGE PLANNING TOOLS FOR THE FIRM.  
MODULE FEATURES ARE:

1. PRESENT VALUE OF INVESTMENTS - TYPE ISHI13SP1
  2. LONG RANGE SALES FORECAST (BASED ON GNP) - TYPE ISHI14SP2
- THESE FEATURES WILL BE DESCRIBED FOR YOU WHEN CALLED.

OVERVIEW OF TOTAL SYSTEM:

TOT  
THIS MODULE OFFERS A TYPE OF OVERVIEW OF THE SYSTEM THROUGH USE OF THE THREE BASIC MODULES. IT IS USED TO COMPARE THE LONG RANGE SALES FORECAST BASED ON GNP AND THE FORECAST BASED ON PERCENTAGE SALES GROWTH. THE RESULTS OF THESE FORECASTS ARE THEN USED IN THE PRODUCTION PLANNING MODULE, AND FINALLY A PROJECTED INCOME STATEMENT IS PRODUCED.

TO OPERATE THIS MODULE TYPE TOT1

Contrasting the above first generation IBM with a third generation (class) results in some interesting insights, particularly in terms of system sophistication and improved output features. Consider an IBM designed to aid the financial planning, scheduling and control of the production of a motion picture.<sup>10</sup> The essentials of this project centered around a PERT/Cost schedule of the activities. The system

included budget projections and critical path (Exhibits 5 and 6), an updating routine and subsequent project performance reports.

<sup>10</sup>Tompkins, G. E., H. D. VanHolth, S. E. Velasco, J.C.G. Gaspar and K. D. Prado, "An Interactive Budgeting Model for Producing a Motion Picture," Term Project, Professor T. J. Mock, Graduate School of Management, University of California, Los Angeles, Spring 1972.

## EXHIBIT 5

Sample Budget Projections  
(for "The Brazilian Connection")

TITLE: THE BRAZILIAN CONNECTION  
DATE OF REPORT: 06/10/1972  
INITIAL BUDGET

ACTIVITY CODE	ACTIVITY NAME	UNIT PRICE (DOLLARS)	QUANTITY	DURATION (DAYS)	SUB-TOTAL 2 (DOLLARS)	SUB-TOTAL 1 (DOLLARS)	TOTAL (DOLLARS)
1.1.0	STORY PURCHASE	100,000.00	1.0	0.0		100,000.00	
1.2.0	SCRIPT WRITER	100.00	1.0	15.0		1,500.00	
1.0.0	STORY AND SCRIPT						101,500.00
3.0.0	DIRECTOR	300.00	1.0	120.0			36,000.00
4.1.0	CAST	200.00	5.0	60.0		60,000.00	
4.2.0	EXTRAS	20.00	10.0	20.0		4,000.00	
4.0.0	CAST AND EXTRAS						64,000.00
6.1.1	DIRECTOR PHOTOGRAPHY	100.00	1.0	80.0	8,000.00		
6.1.2	OPERATORS	30.00	5.0	80.0	12,000.00		
6.1.0	CAMERA						
6.2.1	RECORDIST	30.00	2.0	50.0	3,000.00	20,000.00	
6.2.0	SOUND					3,000.00	
6.3.2	ELECTRICIANS	30.00	2.0	80.0	4,800.00		
5.3.0	LIGHTING, ELECTRICAL					4,300.00	
6.4.1	MAKE-UP, HAIR DRESSERS	40.00	2.0	60.0	4,800.00		
6.4.0	MAKE-UP, HAIR DRESSING					4,800.00	
6.7.1	EDITOR	100.00	1.0	30.0	3,000.00		
6.7.2	NEGATIVE CUTTER	30.00	3.0	30.0	2,700.00		
6.7.3	MUSIC, SOUND EDITOR	75.00	1.0	10.0	750.00		
6.7.0	EDITORIAL					6,450.00	
6.0.0	OPERATING STAFF, CREW						39,050.00
7.1.1	CAMERA EQUIP. RENTALS	10,000.00	5.0	0.0	50,000.00		
7.1.0	CAMERA					50,000.00	
7.2.0	SOUND EQUIP. RENTAL	5,000.00	2.0	0.0		10,000.00	
7.3.1	LIGHTING RENTAL	3,000.00	5.0	0.0	15,000.00		
7.3.0	LIGHTING RENTAL					15,000.00	
7.4.0	MAKE-UP, HAIR DRES. EXP	2,000.00	1.0	0.0		2,000.00	
7.6.0	EDITORIAL EXPENCES	10,000.00	1.0	0.0		10,000.00	
7.0.0	OPERATING EXPENCES						87,000.00
8.0.0	LABORATORY EXPENCES	5,000.00	1.0	0.0			5,000.00
9.0.0	MUSIC EXPENCES	3,000.00	1.0	0.0			3,000.00
							BUDGET TOTAL
							335,550.00

674



Results and Student Feedback

Two sources of data and experiences exist from which the pedagogical effectiveness of the IBM concept may be evaluated. First is the instructor's longitudinal observations over the three classes and comparison with previous courses. From this perspective the IBM simulation seems to be an improved educational aid for the various reasons given in the text of this paper including most importantly:

1. Its experiential nature
2. Reliance on group projects which reflect needed interpersonal and interdisciplinary approaches to system design
3. Replication of real world complexity, time pressures and technical difficulties
4. Ability to obtain an overview and understanding of the entire budgeting system.

Another source of feedback was student course evaluations that were collected in two of the courses. Although such appraisals are the result of a single exposure to the course and although student opinions are anything but consistent, the following critical and supportive quotes do lend positive evidence as to the overall usefulness and difficulties of the IBM in MIS education:

Critical

- "Learned nothing about systems - only APL"
- "Too much time was required with respect to coding"
- "The IBM project was trying to cover too much material"
- "Students tend to underestimate the effort involved in such a project"
- "I learned nothing about planning and control ... too much time was wasted on the IBM"

Supportive

- "IBM was creative and practical application of course subject matter"
- "The IBM ... proved to be quite a meaningful education experience"
- "Contributed much to my understanding of the budgeting process"
- "An enjoyable learning experience"
- "I especially liked working on the project although it does become time-consuming"
- "Great learning experience"
- "IBM was an excellent idea"
- "The IBM was a demanding and interesting experience ... most of the (course) concepts acquired could be used in its design"